

## ALP-2 for DMD Discovery™ 1100

### Accessory Light modulator Package

### Overview

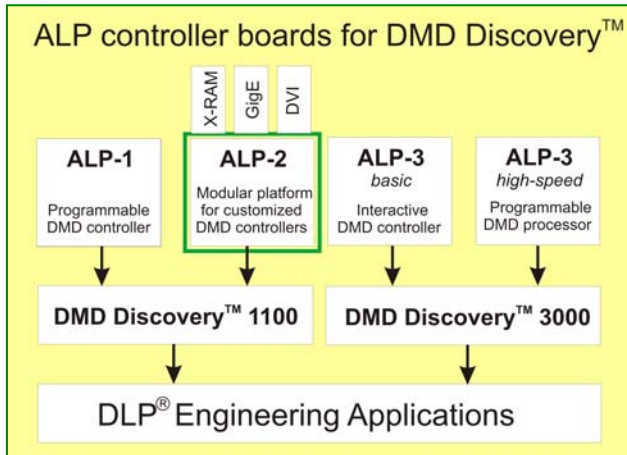

The Digital Light Processing™ of Texas Instruments Inc., represents a proven technology for projection and display applications of the digital micro-mirror device DMD. In addition, the general purpose chipset DMD Discovery™ is a platform for scientists and engineers to develop new engineering applications using Digital Light Processing™. Meanwhile, a variety of DMD components and accessories were made available. The ALP controller boards are accessories for DMD Discovery™ to reach the DMD performance instantly. They provide direct access to the DMD without the need of a dedicated hardware and software development. The ALP line of boards supports the use of the DMD Discovery™ 1100 and 3000 models with high flexibility.

### ALP-2

The *ALP-2* is a controller board for the DMD Discovery™ 1100 parallel interface. It has the same functions and performance as *ALP-1* but provides an additional platform for customized extensions. Different daughter boards can be plugged to *ALP-2* carrying dedicated electronics. In this way, the customer specifications can be implemented without the need of designing a new complex FPGA board. *ALP-2* is connected to the DMD Discovery™ 1100 board using the parallel interface. Customized daughter boards are connected to the *ALP-2* via the 240-pin port on the top. The PC-to-ALP link is USB2.0 based. The *ALP-2* supports the display of both, binary pattern sequences and time average gray level patterns. A user friendly application programming interface (API) is available as a C++ DLL.

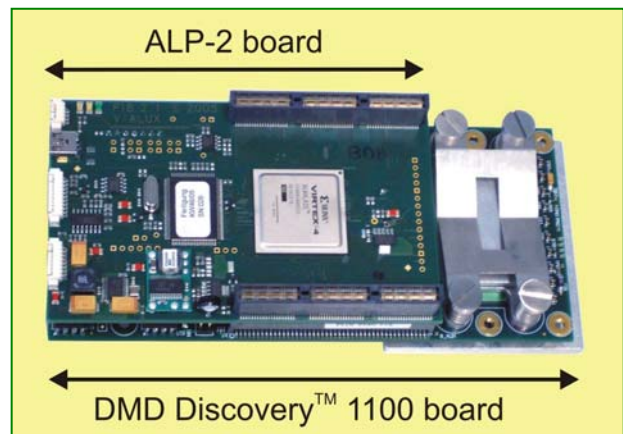

### Principle of operation

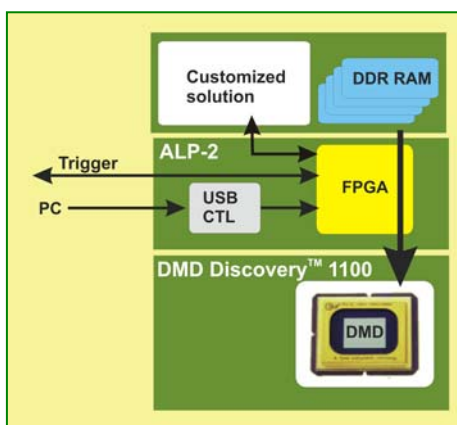

The key part of the *ALP-2* controller board is a Virtex-4 FPGA linking the daughter board to the DMD. The source of data can be different for the various customized solutions. In all cases some amount of DDR RAM will be installed on the daughter board for buffering the patterns. Data input is either through the USB2.0 controller or from an additional customized interface. TTL triggering is provided in both directions, either the *ALP-2* runs in master or slave mode. The DDR RAM is organized in sequences of XGA frames. The *ALP-2* API allows the user to control the data stream and the display timing via the USB2.0 interface. Loading of data can run parallel to the DMD display of other DDR RAM data.

## Application



The ALP-2 architecture serves as a universal platform for a variety of different applications using the same FPGA board that provides the high-speed link to the DMD Discovery™ 1100 parallel interface. Customized hardware solutions require only a dedicated daughter board for ALP-2 and can therefore be implemented faster and at lower costs.

Examples for possible customized applications are:

- Significantly extended RAM capacity (see picture)
- Additional high-speed data interface via DVI
- Additional high-speed data interface via Ethernet
- Camera interface via IEEE1394

## Specifications

### General

dimensions:

ALP-2: 114 x 71 x 8 mm

ALP-2 + DMD Discovery™ 1100 + 32 Gb-X-RAM: 162 x 71 x 77 mm

power supply:

5 V @ 2.5 A (via DMD Discovery™ 1100 board)

operating temperature:

25 ... 45 °C

storage temperature:

-40 ... 80 °C

### Synchronization

ALP-2 master mode:

TTL trigger, pre-trigger supported, trigger programmable

ALP-2 slave mode:

TTL trigger or composite cam signal, programmable trigger delay

### Mirror control

min. ON time:

20 µs

max. ON time w/o any motion:

10 s

max. full XGA frame rate:

8,000 fps

### Variable gray value generation

Table 1: max. XGA frame rate versus bit depth of patterns

Bits per frame	Switching rate [frames per s]
1	8,000
2	3,334
3	2,215
4	1,451
5	936
6	557
7	308
8	162

Table 2: Example of XGA frame capacity for various RAM extensions and different bit depth of patterns

Bits per frame	# of XGA frames		
	32 Gbit RAM	64 Gbit RAM	128 Gbit RAM
1	43,690	87,381	174,762
2	21,845	43,690	87,381
3	14,563	29,127	58,254
4	10,922	21,845	43,690
5	8,738	17,476	34,952
6	7,281	14,563	29,127
7	6,241	12,483	24,966
8	5,461	10,922	21,845

### Delivery package

- DMD Discovery™ 1100 Board or Starter kit (if required)
- ALP-2 parallel interface controller board as platform for the
- Customized controller board with specified amount of on-board DDR RAM
- Connection board and cable for USB 2.0 and trigger interface
- Microsoft® Windows® 2000/XP driver for plug & play ALP-2 operation
- Application Programming Interface (API-DLL)

### Requirements

no special hardware requirements, ALP-2 works with any PC or laptop with USB 2.0 adapter and Microsoft Windows® 2000 / XP operating system

Contact: Roland Höfling, ViALUX GmbH, Reichenhainer Str. 88, 09126 Chemnitz, Germany  
Tel: +49 371 5397 1443, Fax: +49 371 5397 1417, E-mail: [hoefling@vialux.de](mailto:hoefling@vialux.de), [www.vialux.de](http://www.vialux.de)  
For details on DMD Discovery™ see also [www.dmddiscovery.com](http://www.dmddiscovery.com)